

# F\_Prince

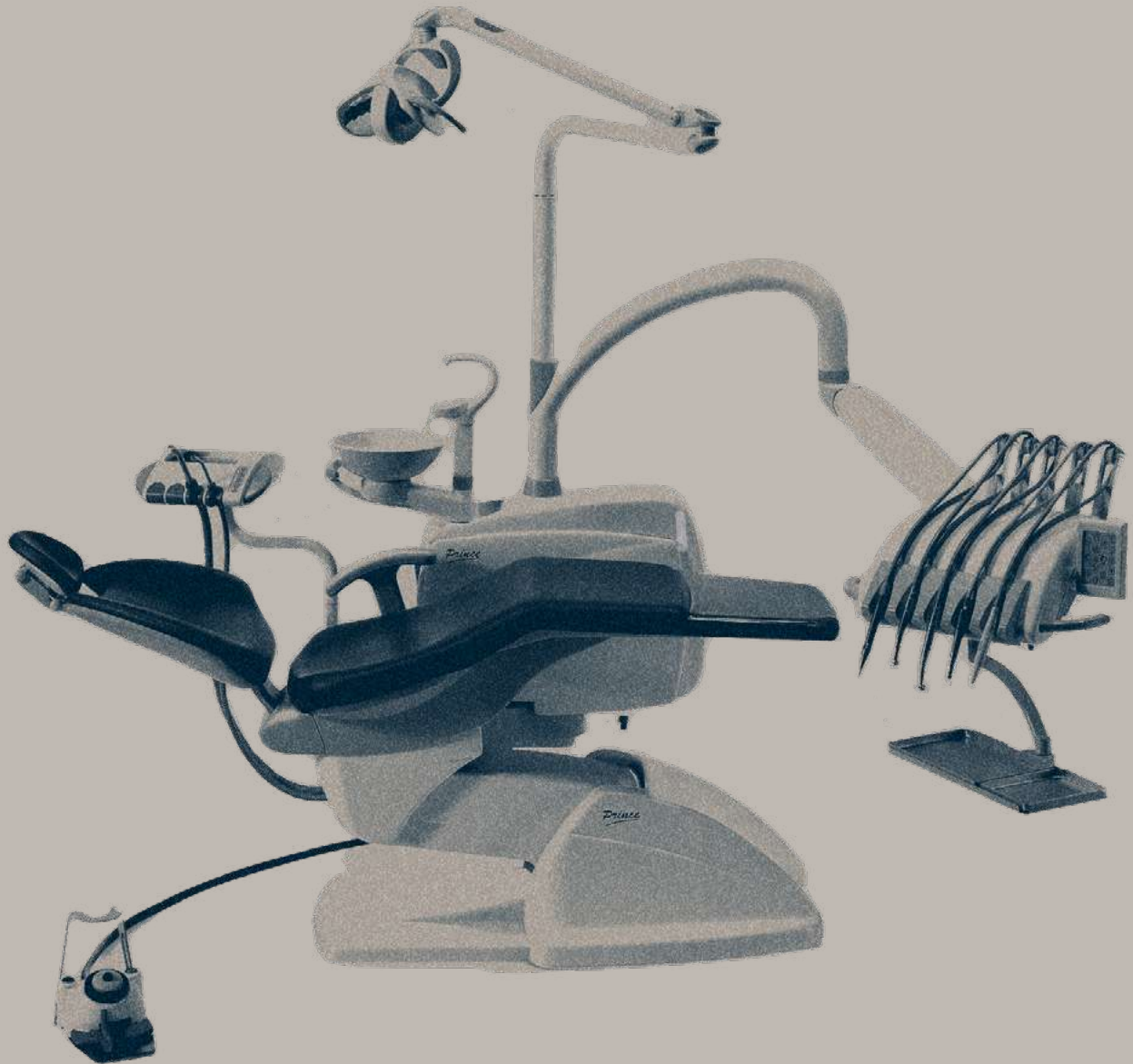

**Fedesa**

# F\_Índice



## Fedesa

Since 1970, two family generations and a large professional team have devoted all their passion and knowledge towards creating the best experience in dental care for dentists and their patients.

We design and manufacture high performance dental units in Spain, in which every component has been developed to be comfortable, efficient and long-lasting.

### **1\_About us**

1.1\_Insights

1.2\_Claim

1.3\_Reasons to believe

### **2\_F\_Prince**

2.1\_Premium

2.2\_Lux

2.3\_Eco

2.4\_Orthodontics

### **3\_Finishes**

3.1\_Textile Colour

3.2\_Upholstery

3.3\_Measures

3.4\_Illumination Lamp

3.5\_Monitor

3.6\_Control Pedals

3.7\_Mobile Units

3.8\_Stools

### **4\_Fedesa**

4.1\_History



# Fedesa

## Your essential teammate, always by your side

FEDESA is a dentist's essential teammate - equipment you can rely on for doing your job and a team that shares the same passion for dental health.

A dental chair always goes alongside a dentist. It's their best ally for inspiring trust and peace of mind in patients.

At FEDESA, we are part of your team, and we are always at your side so that nothing gets in the way of your patients' treatment.

# Fedesa

## High performance, maximum reliability

**FEDESA has been the market leader in high performance dental units in Spain for over 50 years.**

With our experience in design, processes and manufacturing technology, we are able to make high performance equipment accessible to all kinds of clinics.

All our work is focussed on offering you the best experience, service and durability.

Dentist take centre stage and are the core of all that we do. They have a very evident vocation that defines them as individuals.

This vocation is shared by the whole FEDESA team. A family united by a passion to help professionals in the dental sector.

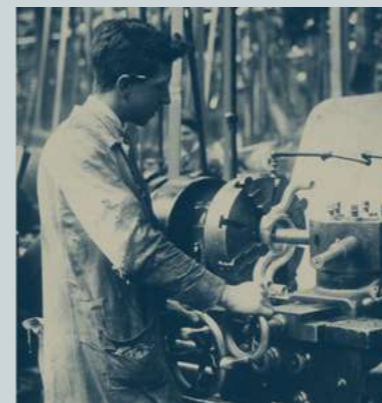

### **A great, leading company that casts its legacy towards the future**

FEDESA has been the undisputed leader of the Spanish market for decades. As well as leading in terms of market share, we are a great company because of our history and the strength of our human resources.

We do not settle for what has already been done. Rather, we look towards the future with an ambition for continual improvement, innovation and sustainability.



### **High performance dental units for the most discerning professionals**

The most discerning dentists choose FEDESA because our high performance dental units are designed and manufactured to be the essential teammate that makes your job easier for many years to come.

We guarantee the performance and durability of our units as a result of our rigorous production processes, quality control and external certifications.



### **A committed, passionate team that is always there for dentists**

The FEDESA team shares the same values that it has transmitted from generation to generation.

All our work aims to make a dentist's job easier.



# For the most discerning professionals

We design and manufacture high performance dental units in Spain, in which every component has been developed to be comfortable, efficient and long-lasting.

  
**60.000**  
units used by  
dentists from 79  
countries.

  
**15** years  
Useful life of

  
**3.200**  
models in stock for  
48-hour dispatch to  
anywhere in Europe

  
**10.000m<sup>2</sup>**  
production and  
development centre  
in Madrid measuring

Dentists treat patients with serious oral health problems. They need to diagnose, treat and follow up with patients until they have recovered.

Dentists also conduct preventative treatments to ensure their patients' oral health.

Just like their patients, dentists need quick responses and the ability to react in adverse circumstances.

We conduct maintenance and follow-up to ensure maximum performance for your equipment.

FEDESA is a dentist's essential teammate, always at their side, sharing the same passion for oral health.

# F\_Prince



## ¿What is the Prince model?



The Prince model is a dental unit that is particularly popular in international markets and enjoys a strong presence in the domestic market. Designed in response to the need for low-maintenance equipment capable of heavy duty use on a daily basis, without affecting its accessibility and reliability.

It features safety systems governing the lowering of the chair, the backrest, circular work station system for the assistant and a user-friendly compensated arm with a wide range of movements.

The novelty in this model is that it includes new configurations for its ranges: PREMIUM, LUX and ECO that, together with the ORTHODONTICS version, cater for a broad spectrum of users based on their different needs.

Each one of the three versions of the Prince dental unit can be configured in three different ways: whiparm/continental type, with hanging hoses and with a mobile unit.



# F\_Prince



## Prince Premium

The **Prince Premium** dental unit incorporates in its basic configuration an independent control panel for the dental unit and for the control of the ultrasonic scaler, LED light on all the instruments, endo induction micromotor, ultrasonic scaler with LED light and a LED type illumination lamp.

Page 14-15



## Prince Lux

The **Prince Lux** model has the same formal and functional specifications as the PREMIUM range, particularly as it is the most popular standard configuration.

Incorporates multi-purpose hoses with lights, an electric brushless or induction micromotor with light and an ultrasonic scaler.

Page 16-19



## Prince Eco

The **Eco version** is a pneumatic unit with the cuspidor and tray attached to the structure of the chair.

It includes a foot pedal to control the speed of the instruments, water selector and chip blower (optionally, you can incorporate a multifunction foot pedal).

Page 20-23



## Prince Orthodontics

The **Prince dental unit** also offers a special configuration for orthodontic treatments. All the instruments required for these purposes can be found in the assistant's work position.

The unit features a multi-function foot pedal to control the speed of the instruments, as well as the independent movement of the chair.

Page 24-25

# F\_Prince

premium

## Prince Premium



The Prince Premium dental unit incorporates in its basic configuration an independent control panel for the dental unit and for the control of the ultrasonic scaler, LED light on all the instruments, endo induction micromotor, ultrasonic scaler with LED light and a LED type illumination lamp.



### Control Panel

All the functions of the dental unit are controlled in an easy and intuitive way. Equally, the parameters of the micromotor (speed, torque, light, direction of rotation, etc.) are also displayed and controlled, as well as those of the ultrasonic scaler (functions: general, endo and perio).

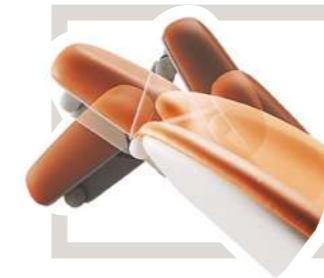

### Headrest

Height-adjustable and double articulation headrest. Its ergonomics allow patients to place their heads in the ideal position for the doctor to work.



# F\_Prince

lux

## Prince Lux



The Prince Lux model has the same formal and functional specifications as the PREMIUM range, particularly as it is the most popular standard configuration. As in the rest of the Prince range, the unit's safety systems ensure incident-free use. Safety system applied to the chair lowering function, to the backrest and to the assistant's work station.

Its user-friendliness, versatility and the reliability of the equipment allow for easy and affordable maintenance. Incorporates multi-purpose hoses with lights, an electric brushless or induction micromotor with light and an ultrasonic scaler.



### Assistant's unit

Includes a tray with four holders on a double-articulated arm that allows the assistant to place the unit in a wide range of positions

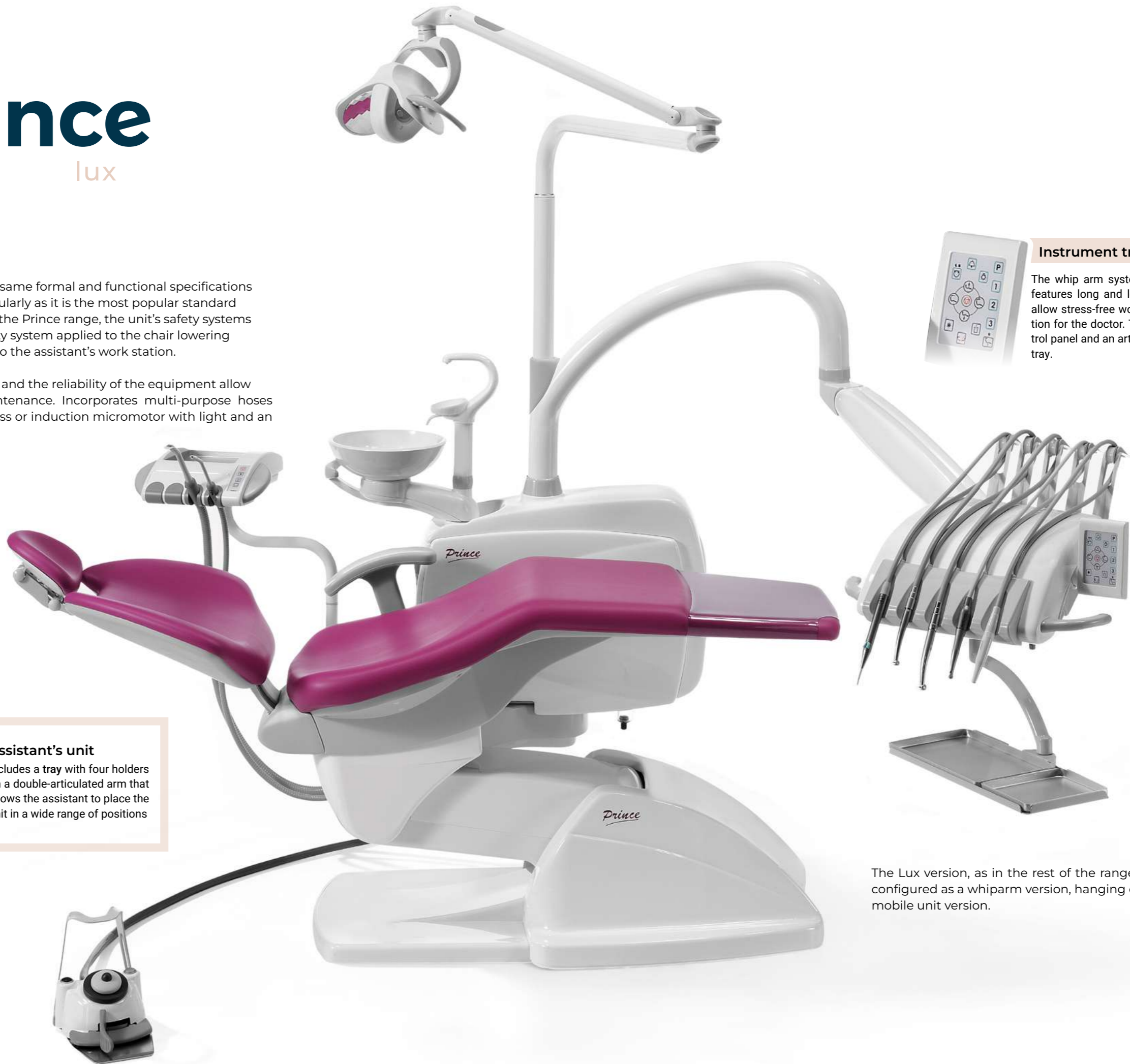

### Instrument tray

The whip arm system instrument tray features long and lockable hoses that allow stress-free work in the best position for the doctor. There is also a control panel and an articulated instrument tray.

The Lux version, as in the rest of the range, can be configured as a whiparm version, hanging or a mobile unit version.

# F\_Prince

lux



## Cuspidor

Incorporates faucets and a bowl. The bowl is made of tempered glass and can be removed to facilitate cleaning, thus providing higher levels of hygiene. The colour of the bowl can be combined with the colour of the upholstery.



## Mobile unit

It is mounted on wheels that provide easy and lightweight handling as well as a wide range of movements to place the unit in any working position required by the operator.

The Prince unit, in its various ranges, Premium, Lux, Eco and Orthodontics, greatly facilitates the work of the doctor and of the assistant thanks to the work spaces provided in its design.



The mobile unit, consisting of an instrument tray with a hanging hoses system, an independent control panel to control all the unit's functions, has a complete pneumatic/electric set of instruments and a top instrument tray.

# F\_Prince

eco

## Prince Eco



The Eco version is a pneumatic unit with the cuspidor and tray attached to the structure of the chair. The assistant's position features a simple tray with two holders (four can be provided on request) and the main tray includes pneumatic instruments with an ultrasonic scaler. It includes a foot pedal to control the speed of the instruments, water selector and chip blower (optionally, you can incorporate a multifunction foot pedal).

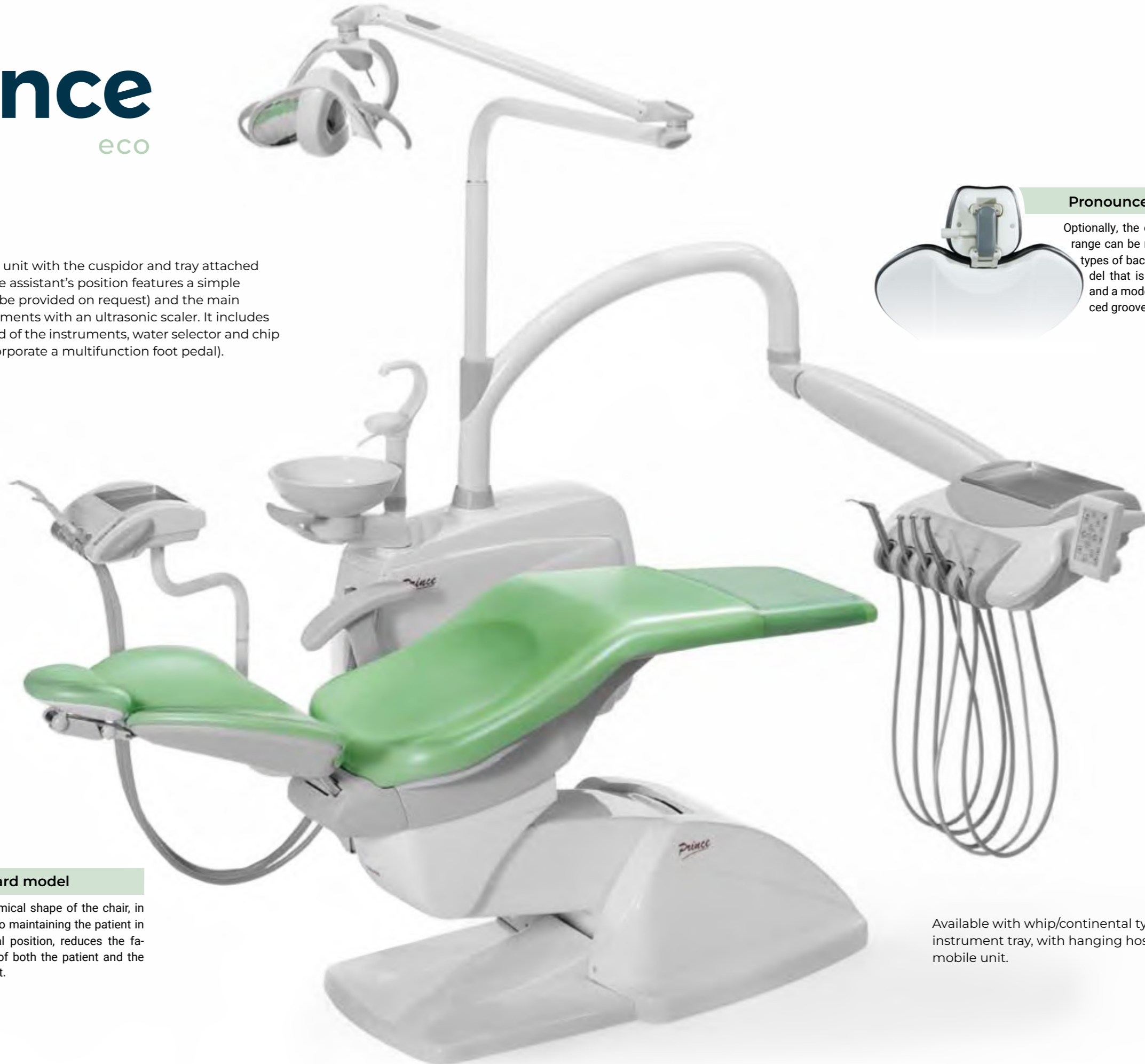

### Pronounced groove

Optionally, the entire Coral dental unit range can be manufactured with two types of backrest: the standard model that is supplied with the unit and a model with a more pronounced groove.



### Standard model

The anatomical shape of the chair, in addition to maintaining the patient in the ideal position, reduces the fatigue of both the patient and the dentist.



Available with whip/continental type main instrument tray, with hanging hoses and a mobile unit.

# F\_Prince

eco

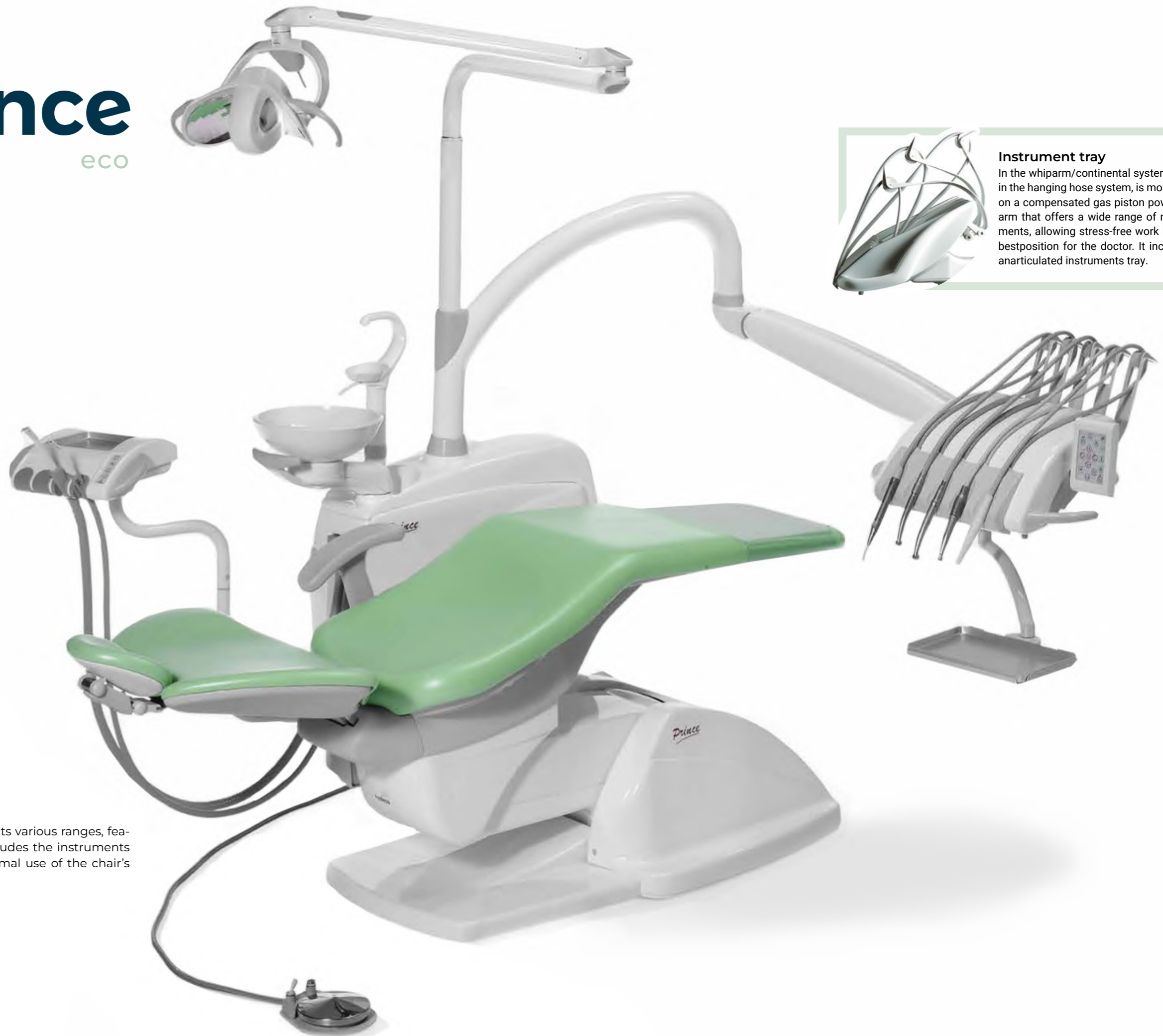

**Instrument tray**  
In the whiparm/continental system and in the hanging hose system, is mounted on a compensated gas piston powered arm that offers a wide range of movements, allowing stress-free work in the best position for the doctor. It includes an articulated instruments tray.

The Prince dental unit, in its various ranges, features a main tray that includes the instruments panel, facilitating the optimal use of the chair's functions.

# F\_Prince

orthodontic

The Prince dental unit also offers a special configuration for orthodontic treatments. All the instruments required for these purposes can be found in the assistant's work position. The water and air syringe, rotary instruments and the suction hoses are fitted to a tray with four holders.

This version also features an instrument tray that is fitted on a double-articulated arm that provides a wide range of movements. The unit features a multi-function foot pedal to control the speed of the instruments, as well as the independent movement of the chair.

Available in two versions of articulated arms.





**Fedesa**

**We are accessible  
to all kinds of clinics**

Dentists take centre stage and they are at the core of all that we do. All our work is focussed on offering you the best experience, service and durability.

With our experience in design, processes and manufacturing technology, we are able to make high performance equipment accessible to all kinds of clinics.

Choosing FEDESA is a matter of trust.

# Finishes

# F\_Coral

## Textile colour finishes that combine with the dental unit

We have selected a wide range of colours for standard use to integrate with modern facilities.



## Upholstery

FEDESA provides upholstery on all its dental units that add to the design of its equipment, improving their convenience and comfort.

Low maintenance flame retardant upholstery without seams, washable and excellent resistance to use.

The extensive catalogue of upholstery colours also comes with viscoelastic upholstery (memory foam).

## Measures of the dental unit

The measurements indicated on the drawing will help you place your equipment in your surgery.

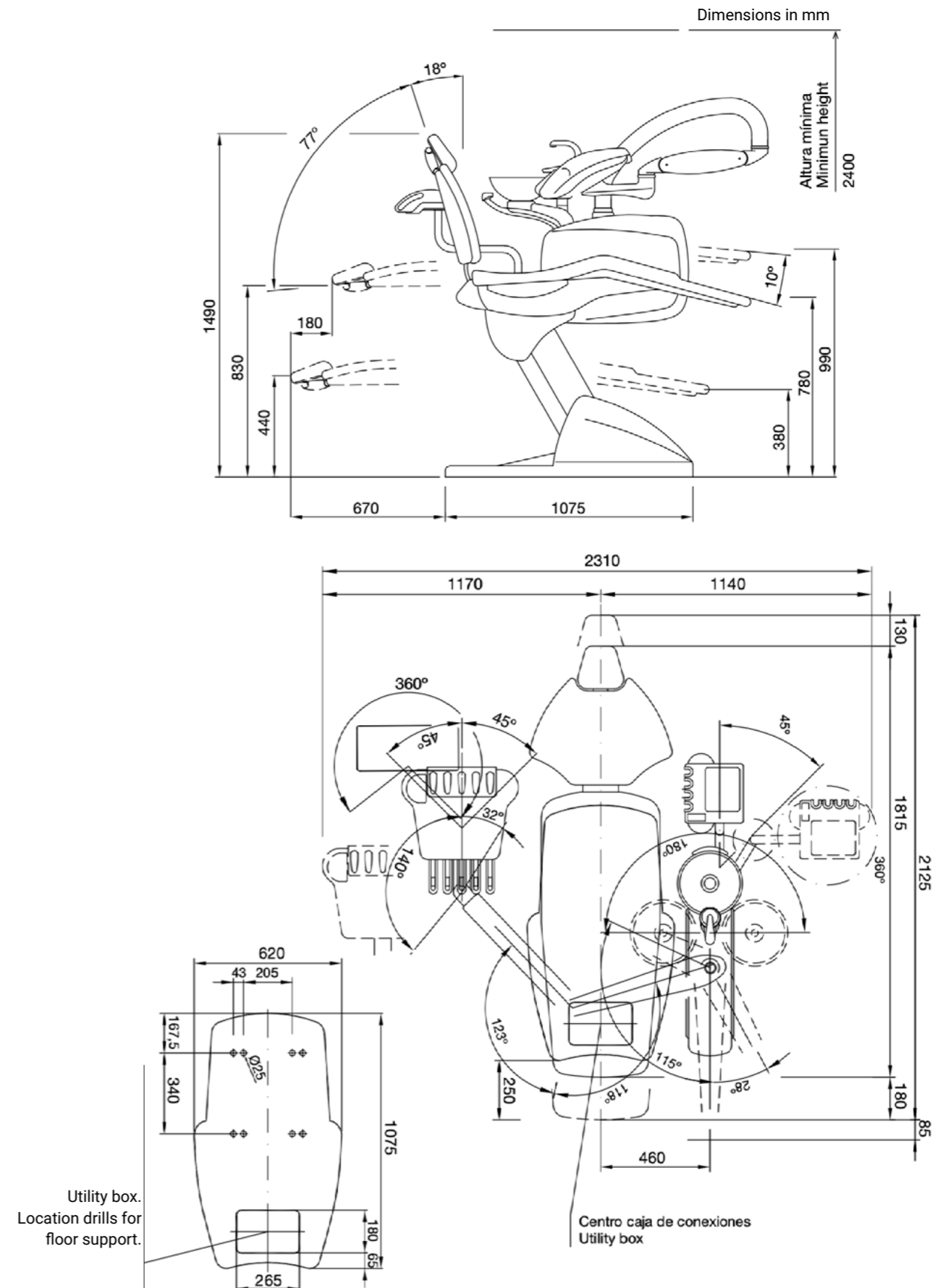

# Options

## F\_Coral

### Illumination lamp

All FEDESA dental units include lighting equipment that can be changed as an option.

EDI Lamp (25,000 lux halogen lamp). MAIA Lamp (35,000 lux LED lamp). ALYA Lamp (50,000 lux LED lamp).



Edi model



Maia model



Alya model

### Control pedals

There are two types: pneumatic pedals with instrument rpm control, water and chip blower selector, and a multifunction pedal for instrument control and to adjust the chair.



Progressive Pneumatic Model



Multifunction Model



Pneumatic Model

### Footrest

All seats on FEDESA units can be supplied with footrests, either with transparent plastic protections or independent polyurethane footrests.



### Monitor

Slim, lightweight, with a 17" screen and adaptable to the various positions required for use by the doctor and patient.



### Intraoral camera

High-resolution camera that can be added to the main tray and to the auxiliary tray. Small and very light, touch activation and detachable.



## Mobile Units

There are various ranges of mobile units: **Premium**, **Lux** and **Eco**. The Premium range features an induction micromotor integrated into the control panel. The Lux range has an electric brush micromotor and the Eco range features pneumatic instrumentation.



Astral Premium Model



Astral Lux Model



Astral Eco Model

## Stools

FEDESA has three types of stools (the **Astral**, **Pony** and **Sory** models) available with or without backrests and with a footrest ring. Surround lumbar support.

They are manufactured in stainless steel and feature a five-wheel base, as well as gas piston height adjustment. A wide range of colours and textures in the upholstery catalogue.



Astral mModel

Astral - A Model



Pony Model with backrest

Pony Model without backrest



Sory Model





# Fedesa

## United by the same passion

Dentists have a very notable vocation that defines them as people. Their profession is in their very DNA. In their nature is a passion to help and to treat patients.

This vocation is shared by the whole FEDESA team. A family united by the passion to help professionals in the dental sector.



### Manufacturing dental units since 1970

From the origins of **FEDESA** back in the 1970s and right up to the present day, we have dedicated our efforts to meet the needs of dentists.

We are experts in designing, manufacturing, and marketing dental units. Our extensive catalogue of solutions caters for all the needs of today's dentists.

Our products meet all national and international regulations and certifications that ensure the quality of all our products. A wide network of agents approved by our brand for the domestic market, as in the rest of the world, collaborate with us to offer the best customer service.



FEDESA is a global company with an unbeatable history in quality, technology and service.

It has an extensive network of distributors all over the world and an excellent professional team that is committed to the company.



# Fedesa

**NUEVA FEDESA, S.A.**

Avda. Madrid, nº 45. 28500 Arganda del Rey (Madrid) España  
Tel.: 34 - 91 871 23 83. Fax: 34 - 91 871 64 88  
fedesa@fedesa.com - www.fedesa.com

FEDESA se reserva el derecho de introducir cualquier cambio en beneficio del producto  
CT9A23-1I. (1000 EJ. 20-03-019)  
Diseño: De Ledesma. Imprime: Gráficas Aries. Depósito legal: M-7XXXXX

# Fedesa

High performance, maximum reliability